

cable passage
passaggio cavi
passagem de cabos
pasacables
passage de câbles
kabel kanal

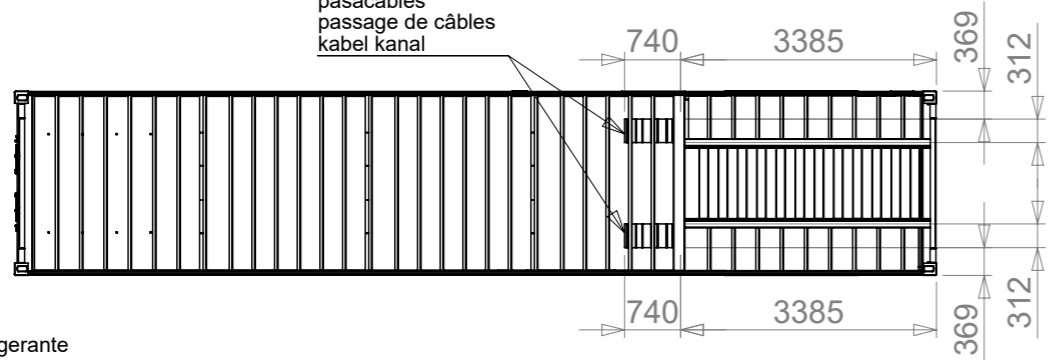

coolant refill
rabocco liquido refrigerante
reabastecimento de líquido refrigerante
relleno de anticongelante
remplissage liquide de refroidissement
Kühlerdeckel

emergency stop
pulsante di emergenza

power panel
quadro di potenza
coffret de puissance
panel de potencia
panel de Potência
leistungspanel

air inlet
ingresso aria
entrada de ar
entrada de altre
entrée d'air
zuluft

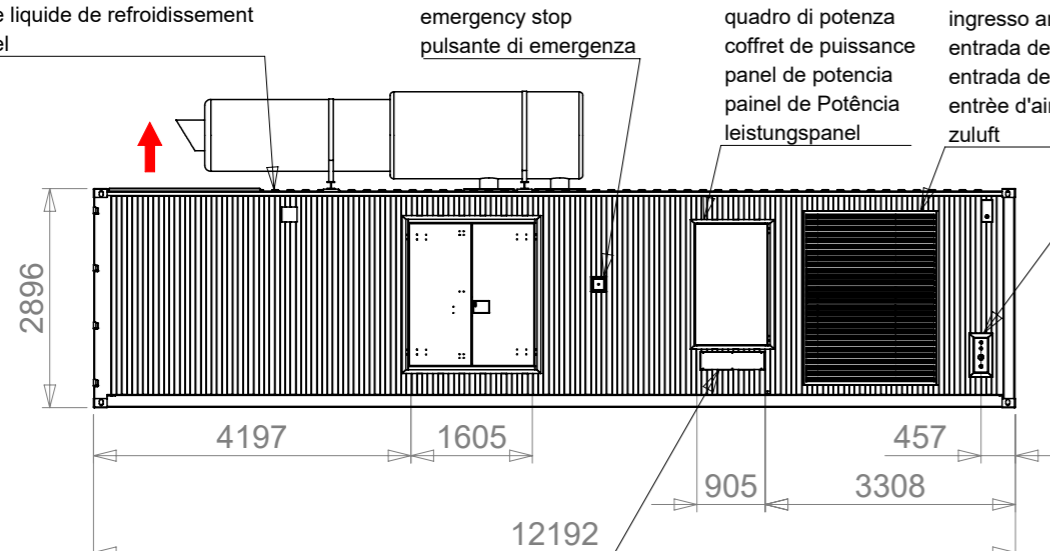

cable passage
passaggio cavi
passagem de cabos
pasacables
passage de câbles
kabel kanal

muffler
marmitta
silencioso
silencioso
silencieux d'échappement
schäldampfer

1144

772

904

air outlet
uscita aria
saida de ar
salida de aire
sortie d'air
abluf

MODEL	DRY WEIGHT [kg]	WET WEIGHT [kg]	CENTER OF GRAVITY (Xg) [mm]
GSW2275M	30175	31219	6173

CONNESSIONI CARBURANTE / FUEL CONNECTIONS

- Connessione mandata carburante G3/4" (dal serbatoio remoto al serbatoio interno) / Fuel delivery connection G3/4" (from remote tank to internal tank)
- Connessione ritorno carburante G1" (dal serbatoio interno al serbatoio remoto) / Fuel return connection G1" (from internal tank to remote tank)

pipng gate to external fuel tank
ingresso tubi per serbatoio carburante esterno
tubo de entrada par reservatório externo de combustível
acceso para rellenado de combustible
passage de canalisations de carburant
anschluss für externen tank

air inlet
ingresso aria
entrada de ar
entrada de altre
entrée d'air
zuluft

emergency stop
pulsante di emergenza

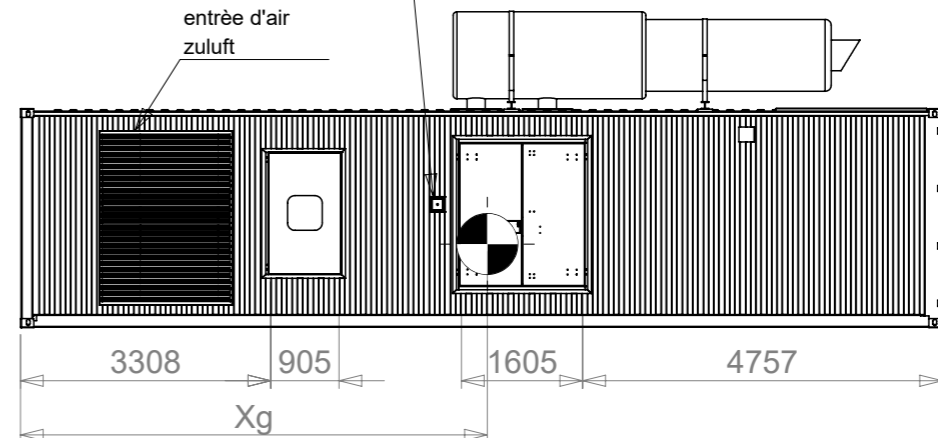
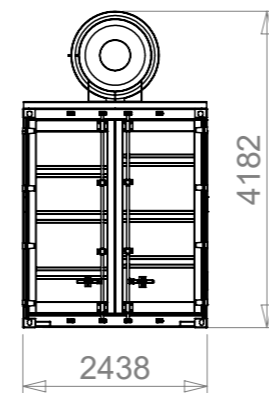

lifting point
punto di sollevamento
punto de içamento
punto de elevación
point de levage
transportaufnahme

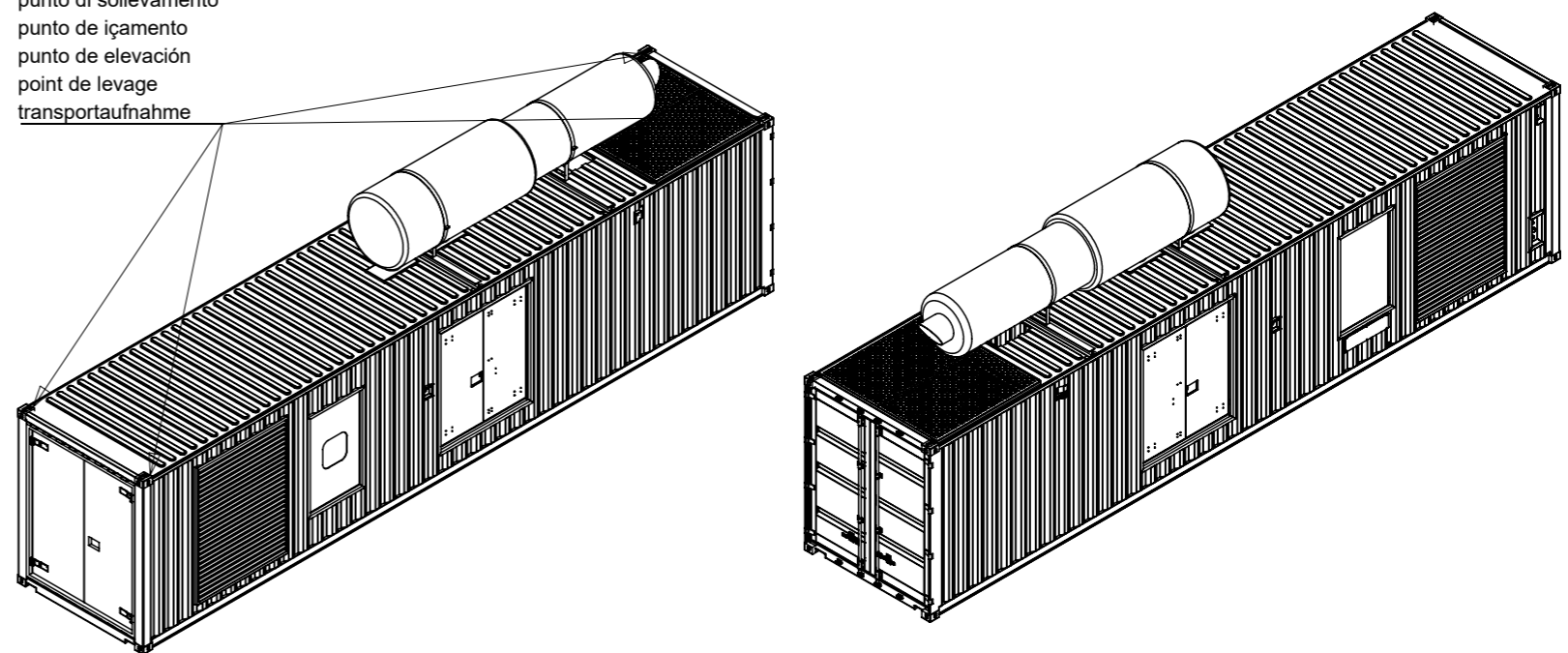

PRELIMINARY



Model
Modello
Modelo
Modelo
Modèle
Modell

GSW2275M



Scale/Scala/Escala/Escala/Echelle/Maßstab 1:100 Code/Codice/Código/Código/Code/Code
Date/Data/Data/Fecha/Date/Datum 16/04/2021 ID0711 00

00 30/03/2021 EMISSIONE

Rev. Date-Data-Data-Fecha-Date-Datum / Modification-Modifica-Modificação-Modificación-Modification-Änderung

This drawing is the sole property of PRAMAC - Any reproduction in part or whole without the permission is prohibited
Il presente disegno è di proprietà di PRAMAC - E' proibita la riproduzione non autorizzata sia parziale che completa